

**EFFECTS OF STOCKING DENSITIES ON GROWTH AND SURVIVAL OF
JUVENILE NILE TILAPIA *Oreochromis niloticus* (Lin, 1758) IN HAPA NETS**

JOHN NDWIGA

**A THESIS SUBMITTED IN PARTIAL FULFILMENT OF THE
REQUIREMENT FOR THE DEGREE OF MASTER OF SCIENCE IN
ENVIRONMENTAL STUDIES (ENVIRONMENTAL BIOLOGY AND
HEALTH) UNIVERSITY OF ELDORET, KENYA**

OCTOBER 2015

DECLARATION BY THE STUDENT

This thesis is my original work and has not been presented for a degree in any other university. No part of this thesis may be reproduced without the prior permission of the author and/ or University of Eldoret.

John Ndwiga **Ref No: SES/PGH/05/06**

Date

This thesis has been submitted with our approval as university supervisors.

Dr. G. M. Simiyu

Date

Department of Environmental Biology and Health

University of Eldoret

Prof. J. Njiru

Date

Department of Applied Aquatic Sciences

Kisii University

DEDICATION

“To Gichimu Kariuki, a brother and friend”

ABSTRACT

A study was carried between October 2008 and February 2009 to evaluate the effect of varying stocking densities on the growth and survival of Nile tilapia *Oreochromis niloticus* stocked in a pond of 100m² and average depth of 1.5m at Chebarus fish farm, Kesess Location, Uasin Gishu County. Tilapia juveniles of mean weight 20±2 g were obtained from University of Eldoret fish farm. The juveniles were randomly stocked at 30, 60 and 90 fishm⁻³ respectively. The fish were fed twice daily at 9.00 am and 3.00 pm with formulated feeds of 40% crude protein. Fifteen, thirty and forty-five fingerlings were sampled from the 30, 60 and 90 fishm⁻³ respectively and analyzed for growth every fourteen days. Physical-chemical parameters like pH, temperature, water depth, total ammonium nitrates and dissolved oxygen were also measured fortnightly using standard procedures. Results showed significant differences ($p < 0.05$) in daily weight gain, specific growth rate, final weight, relative growth rate, feed conversion ratio and survival for all the treatments. Apart from the dissolved oxygen and Total Ammonium Nitrates, all the physical chemical parameters showed no significant differences ($p > 0.05$). There was a major decrease in the levels of dissolved oxygen with increase in stocking density, with the hapa nets containing 90 fishm⁻³ recording the lowest levels of oxygen. Overall, the fingerlings in 30 fishm⁻³ had relatively higher survival and growth rates compared to fish stocked at 60 and 90 fishm⁻³. Low stocking densities of 30 fishm⁻³ stocking are recommended for rearing fish in hapa nets.

TABLE OF CONTENTS

DECLARATION BY THE STUDENT.....	i
DEDICATION	ii
TABLE OF CONTENTS.....	iv
LIST OF TABLES	vii
LIST OF FIGURES	viii
LIST OF PLATES	ix
ACKNOWLEDGEMENTS	x
CHAPTER ONE	1
INTRODUCTION	1
1.0 Background	1
1.1 Statement of the problem	2
1.2 Research objectives.....	3
1.3 Justification of the study	3
LITERATURE REVIEW	5
Hapa net Fish Culture	5
Tilapia culture	8
Growth of Tilapia.....	9
Feeding Habits	10
Temperature Tolerance	11
Salinity Tolerance	11
Water Quality.....	12
Tilapia hapa aquaculture	13
Stocking density.....	15
CHAPTER THREE	17
3.1 Materials and Methods.....	17
3.1.1 The study area	17
3.1.2 Experimental design.....	19
3.1.3 Experimental diet.....	21
3.1.4 Feed formulation.....	22
3.1.5 Proximate analysis	23
3.2 Growth Performance	24
3.3 Water quality parameters	25
3.4 Water Quality Analysis Procedures	25
3.5 Bio-Chemical Water Quality Analysis	25
3.6 Chlorophyll- <i>a</i>	26

3.7 Fish length and weight	27
3.8 Specific growth rate (SGR).....	28
3.9 Survival	29
3.10 Condition factor	29
3.11 Data Analysis	29
CHAPTER FOUR.....	30
RESULTS	30
4.0 Growth performance	30
4.1 Gain in length.....	32
4.2 Gain in weight.....	32
4.3 Length – weight relationships	33
4.4 Food Conversion Ratio	34
4.5 Condition Factor	35
4.6 Survival	35
4.7 Chlorophyll- <i>a</i>	36
4.8 Water quality changes.....	37
4.8.1 TAN-N	37
4.8.2 Dissolved Oxygen.....	38
4.8.3 pH.....	39
4.8.4 Temperature	40
CONCLUSION.....	46
RECOMMENDATIONS	47
REFERENCES	48

ACRONYMS AND ABBREVIATIONS

ADCP:	Acoustic Doppler Current Profiler
AOAC:	Association of Analytical Communities
ANOVA:	Analysis Of Variance
CRSP:	Collaborative Research Support Program
D.O:	Dissolved Oxygen
SGR:	Specific Growth Rate
TAN:	Total Ammonium Nitrates

LIST OF TABLES

	Page
Table 2:1 Environmental conditions favourable for tilapia growth.....	12
Table 3.1 Proximate analysis of the feed composition	24
Table 4.1 Growth performance (Mean±SE) of <i>O. niloticus</i> at three different stocking densities in hapas.	31

LIST OF FIGURES

	Page
Figure 2.1 An illustration of a hapa made of nylon meshes	6
Figure 3.1 Location of Kimondi catchment adapted from GoK (1970)	18
Figure 4.1 Growth in length of <i>O. niloticus</i> stocked at three different stocking densities in hapas in a pond.	32
Figure 4.2 Growth in weight of <i>O. niloticus</i> stocked at three different stocking densities in hapas in a pond.	33
Figure 4.3 Log transformed length-weight relationships of <i>O. niloticus</i> reared in the hapas during the experimental period.	34
Figure 4.4 Trends in condition factors of <i>O. niloticus</i> , stocked at three different stocking densities reared in hapa nets.	35
Figure 4.5 Survival of <i>O. niloticus</i> under three stocking densities in hapa net	36
Figure 4.6 Chlorophyll-a levels under the three stocking densities.....	37
Figure 4.7 Total Ammonium Nitrate in within the hapa nets.	38
Figure 4.8 Dissolved oxygen levels within the hapa nets.	39
Figure 4.9 Variation of average pH values with time.	40
Figure 4.10 Mean weekly temperatures within the hapa nets.	41

LIST OF PLATES

	Page
Plate 3.1 Setting of hapa nets in the ponds	20
Plate 3.2 Measuring and weighing of fish.	27

ACKNOWLEDGEMENTS

My special thanks go my parents, Mr. and Mrs. Nthiga for their wholesome support that they offered during my entire Master's course. Thank you very much for the financial, moral and spiritual support.

I would also like to thank Mr. Cosmas Tamboi and his wife Emily Tamboi for the support they offered me during the entire course of the research. You were really a blessing and played a key role in ensuring the success of this undertaking.

I also wish to thank my colleagues in the School of Environmental Studies for their support, comradeship and encouragement. Your brotherly and sisterly advice gave me the impetus to complete my studies.

May God bless you all!

CHAPTER ONE

INTRODUCTION

1.0 Background

Tilapia are mainly native to Africa, but have been introduced to many countries (Clark *et al.*, 2008). They are hardy, disease resistant and reproduce easily. The tilapia eats a wide variety of foods and tolerates water with low dissolved oxygen levels (Ziková *et al.*, 2010). They are easily spawned, use a wide variety of natural foods as well as artificial feeds and grow rapidly at warm temperatures. These attributes, along with relatively low input costs, have made tilapia the most widely cultured freshwater fish in tropical and subtropical countries.

Tilapia is the second most important farmed fish in the world, after carps (Anderson *et al.*, 2010). Statistics from FAO (2013) show that global supplies of tilapia were estimated to end higher in 2012 than in the previous year, although China, the largest producer, supplied less. African markets remained the focus for completely frozen tilapia from China because demand was strong. The USA has managed to maintain its position as the world's largest market for imported tilapia with imports increasing in 2012 compared with the decline in 2011. The farming of tilapia continues to attract attention from various developing countries in Asia, Latin America and Africa, where most of the production is absorbed by domestic markets. More and more, some leading companies are focusing on certified tilapia, which has been available in the market since August 2012.

As human population increases and natural fisheries resources diminish, fish culture is becoming very important (Jamu, 2008). Many small-scale farmers have failed to

culture fish because of inadequate knowledge such as stocking fry at too small size and at too high density (Kenya, 2007).

1.1 Statement of the problem

The rapidly growing population has triggered a high demand for food which is not always met. This has led to increased poverty levels and as a result malnutrition and starvation. A cheap and simple form of aquaculture may offer a solution to the food shortage crisis. (Ma *et al.*, 2006).

Hapa net culture is simple and cheap way of rearing fish and could be a solution because it utilizes smaller areas of land and it is easier to manage compared to open ponds, tanks and other forms of intensive culture farming. In addition, fish would make for cheap source of protein that would meet the food requirement in the current food shortage crisis (Marshima, 2005). It is within the reach of the poor community who are already hit by the food shortage crisis.

One major disadvantage of hapa nets is that they require constant monitoring to make sure that they do not clog at the bottom and reduce water circulation. Stocking fingerling can also be a major disadvantage to this due to their high vulnerability to mortality. However, there is paucity of information on the performance of the growth of fry and fingerling size of *O. niloticus* during nursery management. Therefore, there is need to find out how fingerling perform when stocked in hapa nets at different densities.

1.2 Research objectives

The overall objective of this study is to investigate the effects of stocking densities on growth and survival of juvenile Nile tilapia (*O. niloticus*) in hapas in ponds.

The specific objectives are:

- i. To determine the effect of stocking density on growth of juvenile *O. niloticus* grown in hapa nets.
- ii. To determine the effect of stocking density on survival of juvenile *O. niloticus* grown in hapa nets.
- iii. To evaluate the effect of physical-chemical parameters on growth of *O. niloticus* grown in hapa nets.

Hypotheses

H₀: Stocking density has no influence on growth performance of *O. niloticus* in hapa nets.

H₀: Stocking density has no effect on survival rate of *O. niloticus* in hapa nets.

H₀: Changes in water quality has no effect on growth of *O. niloticus* in hapa nets.

1.3 Justification of the study

Farmers in Chebarus wetland have been trying net enclosures due to its ability to protect the fish from predators. The cheap cost of construction and easy availability of materials have encouraged the use of hapa net culture. In addition to this, management of these net enclosures is less labour intensive hence its preference.

One key benefit about rearing fish in enclosures is that the fish are protected from predators that reside in the water (Edward, 2008). In addition to this, when tilapia is farmed in high-density hapas, the breeding cycle of tilapia is disrupted. The eggs will

normally fall through the mesh before they are fertilized and eggs that are fertilized will usually fail to develop into fry. This helps control the fish population.

The study focused on tilapia because it has a very high demand (Nakabungo, 2005). It also has a high growth rate and is relatively resistant to handling and stress (Mukoro, 2008). Tilapia is easy to farm in warm climates, leading to inexpensive and safe food in local grocers.

Little is known regarding performance of fish reared in hapa nets. This is with respect to survival and growth. Rearing fish in hapa nets of uniform volume and varying the stocking densities can help establish the growth performance of the fish and hence help advise the farmers accordingly.

CHAPTER TWO

LITERATURE REVIEW

Aquaculture is the fastest-growing food-production sub-sector in the world today (World Fish Centre, 2009), currently supplying half of global fish consumption. Projections to 2020 indicate that demand for fish will continue to grow and that capture fisheries will be unable to respond. Current indications are that aquaculture will need to grow substantially over large parts of Asia and Africa to meet demand for fish. If aquaculture is to grow sustainably and meet its potential for food and income, technologies to meet the needed cheap and efficient mode of production of fish must be developed for key fish species and farming systems. In response, this research places growing emphasis on developing a system that can support this need.

Experience in Asia and Africa has shown the importance of adopting participatory action research approaches to technology development, ensuring that technologies match the natural, capital and educational assets and the aspirations of farmers (Omwansa, 2005). Determining the various roles of the public and private sectors and civil society in technology development and dissemination is vital to scaling out for maximum development impact.

Hapa net Fish Culture

Hapa net fish culture has presumably been originated in the Yangtze River delta in China, approximately 750 years ago (Jamu, 2008). Up to 1978 more than 70 freshwater species have been cultured (Omwansa, 2005) since then hapa culture of fish in freshwater has increased in number more rapidly with time. However, fish production being cultured in fresh water was relatively low with high fluctuations in

yield compared with other fish culture methods (Youssouf *et al.*, 2007). Poor water quality for freshwater fish culture often caused sudden death of hapa fish because of low dissolved oxygen concentration particularly with those intensive hapa cultures, that is, with high stocking density (Wanniggama *et al.*, 2006).

The Hapa culture method of raising fish consists of containers (Figure 1) enclosed on all sides and bottom by materials that hold the fish inside while permitting water exchange and waste removal into the surrounding water. Hapas are constructed in a variety of shapes using materials such as bamboo or wooden slats and wire, nylon and other synthetic meshes. Support structures can hold nets on the water surface or suspended above the bottom of a body of water.

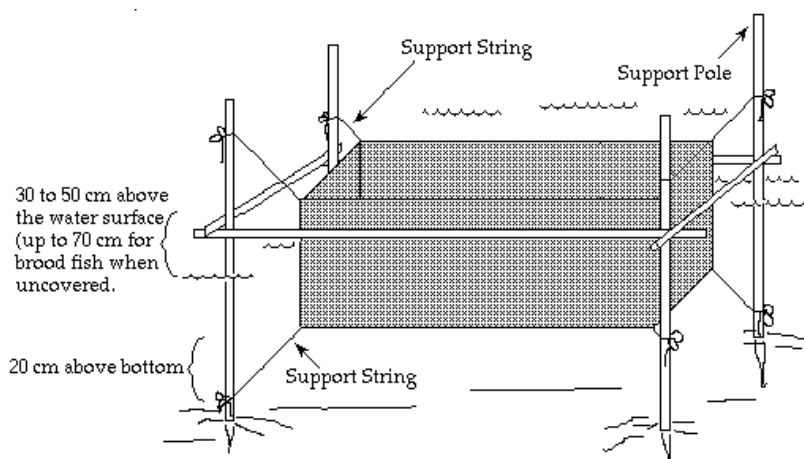

Figure 2.1 An illustration of a hapa made of nylon meshes (Kenya BDS, 2007)

The intentional confinement of fish in hapas to increase their size is a technology dating back to the early 1900s. Today hapa culture is practiced in many regions of the world and is a thriving industry in some areas.

According to World Fish Centre (2009), hapa culture in freshwater normally causes the increasing amount of nutrients in the sediments and water pollutants. In the Philippines, Cato & Brown (2013) showed that an increasing amount of units of hapa

culture with over feeding leads to the deterioration of water quality. In addition, ADCP (2003) reported that hapa culture of Nile tilapia fed with more than 30 % protein contents of feeding stuff tended to increase nutrient loading sediments and they further suggested that the optimum protein level of feedstuff for caged fish was 27%. Nevertheless, Wanniggama *et al.*, (2006) found no significant effect on growth or feed conversion ratio among Nile tilapia with the average sizes from 22 to 30 g live weights.

New (2010) asserts that the impact of hapa culture in terms of nutrient loadings could presumably be divided into two points. First, it increases nutrient concentration in environment, if intensive hapa culture is carried out with the use of complete diets; and two, it could reduce nutrient concentration in environment, if the extensive hapa culture is fed by natural foods. Nevertheless, Houlihan *et al.* (2013) stated three culture methods, with hapa fish culture using silver carp and bighead fingerlings. The methods are; (1) nursing the fish in hapas without supplementary feeding; (2) culture the fish in fertile water, based on natural feed with aquatic macrophyte supplementation; and (3) culture the fish with complete feeding at high stocking density. He further stated the impact of hapa fish culture research as (1) the examination of environment between hapa area and control area, (2) the quality of environment before, on going, and after hapa culture. Most of the publications are concerned on the increasing amounts of PO_4^{2-} , NH_4^{4+} , organic matter, organic nitrogen and the reduction of dissolved oxygen (New & Valenti, 2013). Whilst other research investigations involved mostly the impact of hapa culture with respect to oxygen consumption, nitrogen, phosphorus and organic matter in the bottom sediments (New & Valenti, 2013).

Tilapia culture

Tilapias have been raised as food fish, for human consumption for many years and recently it has become very important as ornamental fish and as a research animal for biotechnology, seaweed treatment, weed control in ponds and in rice fields (New, 2010). Tilapias have been transplanted to many countries outside their native land worldwide. Their farming is now in a dynamic state of worldwide, expansion to satisfy the demand from both domestic and international markets, to provide an affordable source of animal protein, and for vegetation control (Mukoro, 2008).

In the tropical and sub-tropical countries, tilapia has been identified as the ideal culture species and its research and culture is rapidly increasing (Green, 2009). Great attention has been paid to the production of grow-out (table size) fish in high intensity culture systems such as raceways, tanks or cages. The main challenges in tilapia culture in Kenya are low fish production per water unit from the extensive and semi-intensive culture units, high unaffordable costs in intensive farming techniques and impractical and limited implementation of the current population control techniques of *O. niloticus* (Ois, 2010).

The current methods used in the population control are sexing fry at an early stage, hybridisation, hormonal sex reversal, genetic manipulation, use of genetically improved tilapia, use of predator, and rearing a mixed male-female population of young of the year (Cato & Brown, 2013). However, most of these techniques are difficult to be used by farmers in large-scale fish production, as they require a hatchery operated by trained personnel (Gibson, 2005). The high intensity tilapia aquaculture methods in use are raceways, tanks or cages. Tank and raceway tilapia

culture are more developed than cage and hapa culture. In intensive culture, fish are held in high densities of 200-400 fish m³ in raceways, tanks or cages and given high quality feed for rapid growth. All the three systems require a species of fish that grows rapidly, accepts artificial feeds, tolerates crowding and has a high market value. These methods differ only in the methods of delivering fresh water to the fish and removing wastes. In raceway and tank culture, this is accomplished in a steadily high volume flush of fresh water and sometimes-mechanical aeration.

In cage culture, the cages are floated at the surface of a body of water, and are constantly flushed by currents without mechanical aid (Giorgio & Williams, 2005). Although the savings of land and labour are the major advantages of the systems compared to pond intensive farming, the cost of feed and technology is high. Except for cage and hapa culture, which are thought to be the most effective of the three systems if suitable sites are available, the other systems require very high capital investment and technology, which a common farmer cannot afford (Gregory & Grandin, 2013).

Growth of Tilapia

Nile tilapia is a tropical species that prefers to live in shallow water (Gregory & Grandin, 2013). The lower and upper lethal temperatures for Nile tilapia are 11-12 °C and 42 °C, respectively, while the preferred temperature ranges from 31 to 36 °C. It is an omnivorous grazer that feeds on phytoplankton, periphyton, aquatic plants, small invertebrates, benthic fauna, detritus and bacterial films associated with detritus. Nile tilapia can filter feed by entrapping suspended particles, including phytoplankton and bacteria, on mucous in the bucal cavity, although its main source of nutrition is

obtained by surface grazing on periphyton mats. Sexual maturity in ponds is reached at an age of 5-6 months. Spawning begins when the water temperature reaches 24 °C. The breeding process starts when the male establishes a territory, digs a craterlike spawning nest and guards his territory. The ripe female spawns in the nest, and immediately after fertilization by the male, collects the eggs into her mouth and moves off. The female incubates the eggs in her mouth and broods the fry after hatching until the yolk sac is absorbed. Incubating and brooding is accomplished in 1 to 2 weeks, depending on temperature. After fry are released, they may swim back into her mouth if danger threatens. Being a maternal mouth brooder, the number of eggs per spawn is small in comparison with most other pond fishes. Egg number is proportional to the body weight of the female. A 100 g female will produce about 100 eggs per spawn, while a female weighing 600-1 000 g can produce 1 000 to 1 500 eggs. The male remains in his territory, guarding the nest, and is able to fertilize eggs from a succession of females. If there is no cold period, during which spawning is suppressed, the female may spawn continuously. While the female is brooding, she eats little or nothing. Nile tilapia can live longer than 10 years and reach a weight exceeding 5 kg (Clark *et al.*, 2008)

Feeding Habits

For their sustenance, newly hatched fry depend on their yolk sacs until consumed. They then eat the smallest phytoplankton present in the pond (Edward 2008). As the fry become bigger, they eat larger organisms and supplemental feeds such as rice-bran, fishmeal and others. Tilapia feed on a variety of phytoplankton as their primary food items (Anderson *et al.*, 2010). They are cannibalistic and will feed on their fry if food is not abundant (Anderson *et al.*, 2010). The tilapia has a short oesophagus

leading to a small sac-like stomach with an exceptionally long intestine (4x the body long). The *O. niloticus* has firm pharyngeal teeth set on a triangular blade. Its role is to prepare food for digestion, shredding the coarser materials and breaking some of the cell walls before passing it on to the stomach.

Temperature Tolerance

Tilapia cannot tolerate temperatures below 10⁰C. Temperature of about 20 – 25⁰C, however, could still suppress growth. Low temperature is usually felt in upland areas, but this is normally not a problem in the tropics. *Oreochromis aureus* shows better growth tolerance at a lower temperature as compared to other tilapia species. All tilapias can tolerate high water temperature. However, too much handling at high temperature could result in high mortality. The best temperature range for *O. niloticus* is between 25⁰C and 30⁰C (Gregory & Grandin, 2013). This ensures that there is no stunted growth and prolific reproduction.

Salinity Tolerance

Most tilapias are relatively euryhaline (can tolerate a wide range of salinities). *Oreochromis niloticus* can tolerate seawater if properly acclimated. However, their spawning may be suppressed at salinities between 15 and 35 parts per thousand (ppt). Besides, their growth in saline waters is not similar to that in freshwater. *Oreochromis massambicus* can tolerate salinity changes much better than *Oreochromis niloticus*, and can reproduce at high salinities. *Oreochromis aureus* seems to be a little more euryhaline than *O. niloticus*, but not as tolerant as *O. mossambicus* (Clark *et al*, 2008).

Water Quality

Tilapias are extremely hardy fish and can withstand adverse water conditions. However, good water management is the key to successful fingerling and food fish production. The water quality should be monitored regularly. Below are some of the favourable conditions for growth of tilapia (Gregory and Grandin, 2013).

Table 2:1 Environmental conditions favourable for tilapia growth

Parameter	Level	Comments
Temperature	25 – 30 °C	Optimum for reproduction and growth
DO	8 - 10 (mgL ⁻¹)	For optimum growth
Salinity	10 – 15 (ppt)	Favour growth
pH	6.5 – 9	Optimum for primary reproduction
CO ₂	2 (mgL ⁻¹)	For optimum growth
Total ammonia	0.02 – 0.5 (mgL ⁻¹)	For optimum growth
Turbidity	30 – 35 units (NTU)	Silt can damage gills
Water current	20 units	For intensive culture flow-trough system

Adopted from World Aquaculture Centre (2012)

The aim of aquaculture is to obtain possible maximum yield of culture organism through approximate control of physical, chemical and biological factors and through proper management in the most economical way. Besides other efforts, it involves control of the number of the selected culture organism per unit volume of water in relation to prevailing physical chemical parameters appropriate feeding and prevention and or action against disease parasites and predators (Gregory and Grandin, 2013).

The simplest form of aquaculture is stocking natural waters or ponds with no artificial feeding. Improved production is obtained through fertilization and supplemental

feeding. Hapa culture has a number of advantages, predation is controlled, stocking density is known and mortality rate can be estimated. Growth rate can be estimated in terms of weight and length (Edward 2008).

Tilapia hapa aquaculture

South East Asian fishermen started hapa culture in 1800 in Kampuchea and modern cage culture began in the 1950s in Japan, with the advent of the synthetic material for cage construction and cage culture in Marine waters gained ground in 1990s (Jamu, 2008). The practice of hapa culture has spread throughout the world to more than 35 countries in Europe, Asia, Africa and America and by 1978, more than 70 species of fresh water fish had been experimentally grown in cages (Kenya, 2007). Currently many fish species have been cultivated in various designs and sizes of cages in Asia, Europe and many parts of the world. Tilapia and carp predominates in fresh water hapa culture in Asia while salmonids are commonly farmed in Europe and Americas (Ma *et al.*, 2006). Hapa culture of tilapia begun in Auburn University Alabama, in late 1960s with the rearing of *Sarotherodon aureus* in hapas placed in ponds, and it has spread widely to several tropical countries of Africa, Asia and Latin America. In North America, it is confined to the state of Alabama. (Ma *et al.*, 2006).

In South America, Brazil dominates the tilapia hapa culture industry and commercial cage culture operations are the major suppliers of the fish sold within and outside Brazil (Marshima, 2005). In Belgium, it is practiced at the thermal effluent of a nuclear power station (New and Valenti, 2013). In Asia, the Philippines it is the pioneer for hapa culture in lakes and reservoirs in the region and practices semi-intensive and intensive farming (Marshima, 2005). Thailand and Indonesia practice tilapia cage and hapa culture of red tilapia in rivers, irrigation canals and

lakes/reservoirs, at semi-intensive and intensive levels (Nakabungo, 2005). In Israel, the first hapa culture began in Lake Bunt in the San Pale Lake areas of Laguna Province in 1975. By 1984, they were producing 10,000 tons of tilapia per annum in hapas. (Nakabungo, 2005)

Hapa culture in Africa is at its infant stages and exists as pilot or free operational project at subsistence, commercial and on experimental basis in marine, brackish and fresh water environments (Mukoro, 2008). The first tilapia hapa culture experiment in Africa was conducted in 1972, using *Oreochromis esculentus* and *Tilapia zillii* in Tanzania Lake Victoria followed by that of *O. niloticus* in the Ivory Coast in Lake Kossou (New and Valenti, 2013). In central Africa, it started in 1974 (Mukoro, 2008). The largest operational hapas in Africa is in Northern Zimbabwe (Omwansa, 2005). Uganda announced her decision of starting hapa culture despite the warnings against environmental deterioration caused by cage and hapa culture (Omwansa, 2005).

In Kenya, hapa culture is widely and successfully demonstrated in different parts of the country (Youssouf *et al.*, 2007). It is found in ponds, dams and other water bodies along the shores of Lake Victoria, for example Dominion in Yala swamp, Central, Eastern and North Rift provinces of Kenya, Mukoro (2008). It is postulated that hapa culture will contribute to as much as 90% of all farmed fish in Kenya by both volume and value in the coming years (Kenya BDS, 2007). Other hapa operations conducted on experimental basis in Kenya are; a research conducted in Machakos district (Nakabungo, 2005), Malindi (Mashirma, 2005), Sagana (Wanniggama *et al.*, 2006). Floating cages are also used in Kenya as holding units in culture farms like Sagana, Kiganjo and University of Eldoret.

Stocking density

In terms of the fish production in hapas, stocking density, which is related to the volume of water or surface area per fish is an important factor. Increase in stocking density results in increasing stress, which leads to higher energy requirements, causing a reduction in growth rate and food utilization (World Fish Centre, 2009). On the contrary, in case of low stocking densities fish may not form shoals and feel comfortable. Consequently, identifying the optimum stocking density for a species is a critical factor not only for designing an efficient culture system (World Fish Centre, 2009), but also for optimum husbandry practices. Controlling the fish size and production are the two important tasks to meet the market demands, but increase in stocking density to produce more fish, which increases fish intensification, may not be the best way of dealing with problem of space shortage.

In many cultured fish species, growth is inversely related to stocking density and this is mainly attributed to social interactions (New and Valenti, 2013). Social interactions through competition for food and/or space can negatively affect fish growth. On the other hand, the price of fish is determined by the market demand of supply (size and production), that in turn depends on their growth. Cato and Brown (2013) suggested that, in intensive aquaculture the stocking density is an important indicator that determines the economic viability of the production system.

The national fish production updates indicate there has been a decline in fish caught in the country's lakes for the past decade. The updates indicate that the trend has sharply risen in the last four years. Reduction in fish species diversity in Lake Victoria, which provides 90 percent of the annual national production, the degradation of the fish

habitat, and the spread of aquatic weeds such as the water hyacinth have been cited as the major causes of the decline in per capita supply of fish.

In addition, over-fishing caused by an influx of anglers to the country's lakes because of unemployment has been blamed for the bad state of affairs. A recent report on Lake Victoria released by the Kenyan Ministry of Livestock and Fisheries Development indicates that the Kenyan part of the lake, which is only 6 percent of the lake's area, has 55,000 anglers, which is more than double the recommended figure. Demand for fish continues to rise with the increase in population. With a decline in fish obtained from their natural habitat, fish farming is likely to expand, hence the purpose of this study.

CHAPTER THREE

MATERIALS AND METHODS

3.1.1 The study area

The study was carried out at the Chebarus wetland, Kesess district, Rift Valley Province, Kenya. Chebarus wetland is a sub catchment of the Kimondi-Kingwal wetland. Kimondi catchment lies between $0^{\circ} 14'$ and $0^{\circ} 35'$ north and longitudes $35^{\circ} 00'$ and $35^{\circ} 25'$ east of the Greenwich. It is bordered to the north by Uasin Gishu Plateau, to the east by northern Tindiret and Nabkoi forests, to the south by Nyando Escarpment and to the west by Nandi Escarpment and Nandi North forest (Figure 3.1). It is characterized by a high relief with an altitude of between 1780m and 2660m above sea level (Houlihan *et al.*, 2013).

The catchment experiences a cool and moderately wet climate with rainfall ranging between 1200-200mm per year. The long rains start in March and end in June while the short rains commence in September and end in November. A dry spell is normally experienced between December and March. The topography influences the character of the south-westerly winds from Lake Victoria, which in turn influences the distribution of rainfall in the catchment (Boyd and Tucker, 2008).

The landscape characterized by the occurrence of riverine wetlands and numerous streams, which meander forming Kimondi River, a major tributary of River Yala. The streams form a good drainage in the area and given the perennial discharge of the streams, the availability of adequate water for domestic use is guaranteed, though threatened by increasing wetland loss (Juma, 2011).

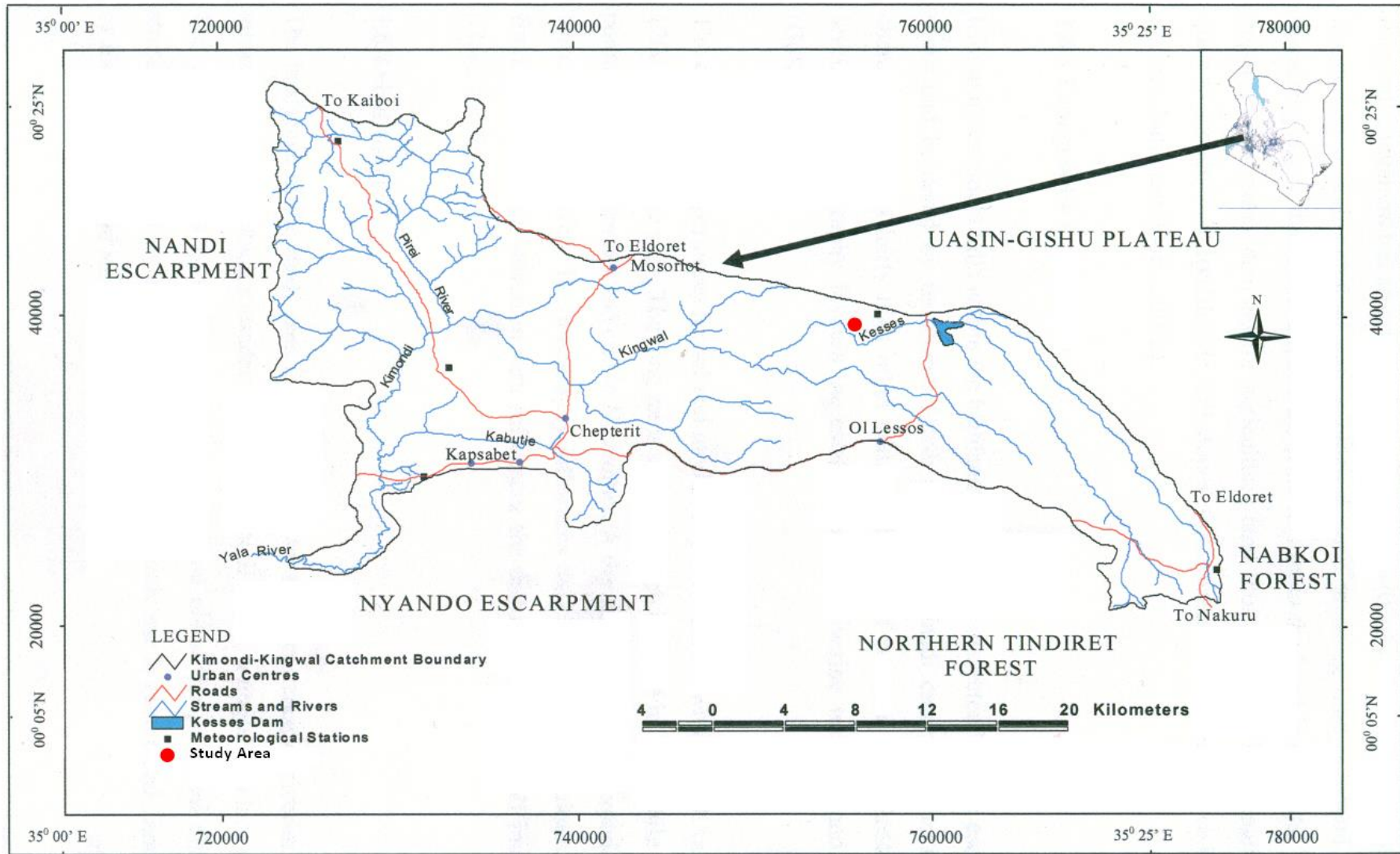

Figure 3.1 Location of Kimondi catchment adapted from GoK (1970)

The soils are humid with vegetation cover of moist forest type of vegetation. According to Juma (2011), the soil types in the swamps have originated from igneous rocks and basement rocks, which are poorly drained, dark, grey atloid clays with humus topsoil. Shisia and Ngure (2011) describe these soils as relatively rich in organic matter and hence have moderate to high fertility.

3.1.2 Experimental design

The experiment was carried out from 20th October 2008 to 20th February 2009. Eighteen hapas were stocked with Nile tilapia, *O. niloticus* in three ponds of approximately 100m² at Chebarus Fish Farm (Plate 3.1). Twenty day old brood stock fingerlings of both sexes with an average weight of 20±2g and size of 20±2cm TL were obtained from the then Moi University, Chepkoilel Campus fish farm, [now University of Eldoret].

Hapas were constructed of nylon mesh, which is inexpensive, durable, lightweight and easy to handle. The nylon meshes size of 1.5 x 1.5mm. The netting material was sewn together to form a one meter square enclosure with an allowance of 30cm height to make sure the fish do not jump out of the hapa net. The hapas were then submerged to a depth of 1m. On the sides, they were held in place by four supporting holders at the corners then fastened to the floor of the pond. An allowance of 30cm was left from the bottom of the floor to ensure no clogging would take place due to sedimentation and ease water circulation.

The experiment was carried to find out the performance of *O. niloticus* stocked at different stocking densities in hapa nets measuring 1m^3 . Randomization was done to eliminate parameter bias due to exogenous factors. Completely Randomized



Plate 3.1 Setting of hapa nets in the ponds (Source : Author 2008)

Block design was employed in this experiment. Nine small pieces of papers were assigned numbers denoting each hapa. Those that were to represent 30 fish were assigned numbers 3a, 3b, and 3c those that were to represent 60 fish were assigned numbers 6a, 6b, and 6c and those that were to represent 90 fish were assigned numbers 9a, 9b, and 9c. They were then folded and put in a small can mixed and then picked at random. The hapa nets were first fastened into position within the pond then fish of uniform sizes (20g), were then stocked depending on which stocking density would be picked from the can.

All the experimental hapas were stocked on the same daytime at relatively the same time. The average stocking size of the fingerlings was 30 fishm^3 , 60 fishm^3 and 90 fishm^3 in replicates.

3.1.3 Experimental diet

The constituents of the fish were *Rastrineobola argentea* (fishmeal) and rice bran. The two were bought from Eldoret town and sun dried for 10 days. They were individually ground into fine dust using electrical grinding mill. Proximate analysis of 500g of each of the ingredients was conducted at the Fisheries and Seed Technology Laboratories at University of Eldoret using the standard methods (AOAC, 2000).

The analysis of crude protein was conducted using the Kjeldah method (AOAC, 2000) and calculated using the formula

$$\text{Crude protein} = N * 6.25$$

Where N = Total N content in the diet

The crude lipid was determined by continuous extraction using petroleum ether at 40⁰ – 60⁰ C and diethylether at 34⁰C – 50⁰C in Soxhelt for eight hours (AOAC, 2000). The ash content of each was determined by incineration of the pre-weighed sample in a silica crucible in a muffle furnace at 600⁰C for six hours (AOAC, 2000). The alkaline acid method and a drying oven at 640C also obtained the crude fibre and the moisture content for 24 hours respectively.

To obtain total carbohydrate, a calculation using the value from the difference of 100% and the percentage sum of all measured values was done as follows,

A hundred percent - percentage crude protein + percentage ether extract (fat) + percentage crude fibre + percentage ash.

The fine ground proportions of each ingredient were measured in the required amount 500g each, divided into the required amount for each experiment, and used for proximate analysis.

3.1.4 Feed formulation

The appropriate amount of each ingredient required to standardize the protein levels at 32% crude protein during the feed formulation was calculated using the Pearson's square method. The proportions required were 41% fishmeal and 59% rice bran in order for the rice bran to complement the fishmeal for the supply of energy. The finely ground proportions of each ingredient were measured in the required amounts and mixed in the ration of 3kg rice bran to 2kg *R. argentea* respectively to give 32 % crude protein respectively.

The resultant mixture of dry feed component was blended, moistened with water kneaded with water until stiff dough was formed. Equal proportions of sunflower oil and Nile perch liver oil (1:1) were added as lipid source in the test diets before being extruded in a meat mince. The resulting strands were sun dried initially before being dried at 60⁰C in an oven for 24 hours. Dried pellets were crumbled into suitable lengths, stored in airtight plastic containers at ambient temperature in a cool and dry place, and fed within two weeks of production to avoid deterioration in quality through rotting.

The resultant feed was divided proportionally according to the number of fish in each hapa net and further subdivided into two feeding rations of 5% body weight and given twice per day. Since the experiment was conducted in fertilized earthen fishpond, the required vitamins and minerals mix was assumed to be supplied from the natural food (New, 2010) and therefore the diet was not mixed with any standard 0.1% vitamin mineral pre-mix.

3.1.5 Proximate analysis

The proximate analysis of the resultant formulated feed pellets was determined at University of Eldoret, Fisheries and seed technology laboratories according to AOAC (2000). First the feeds were weighed and the initial weight taken, they were then heated to a 100⁰C to rid of the moisture content and then weighed. The dry feeds were then heated in an oven for six hours at a temperature of 550⁰C to get rid of carbon then the weight taken.

Crude protein was then estimated using Kjeldhal method. The food was digested with sulphuric acid, which converts to ammonia all nitrogen present to form nitrate and nitrite. This ammonia is liberated by adding sodium hydroxide to the digest, distilled off and collected in standard acid, the quantity so collected being determined by titration. It is assumed that the nitrogen is derived from protein containing 16 per cent nitrogen, and by multiplying the nitrogen figure by 6.25 (i.e. 100/16) an approximate protein value is obtained.

The ether extract (EE) fraction was determined by subjecting the food to a continuous extraction with petroleum ether for a one-hour period. The residue, after evaporation of the solvent, is the ether extract.

The carbohydrate of the food is contained in two fractions, the crude fibre (CF) and the nitrogen-free extractives (NFE). NFE was determined by subjecting the residual food from ether extraction to successive treatments with boiling acid and alkali of one molar concentration; the organic residue is the crude fibre.

The results are as shown in the table below.

Table 3.1 Proximate analysis of the feed composition

INGREDIENT	%
<i>R. argentea</i> fish meal	20
Rice bran	25
PROXIMATE ANALYSIS	
Moisture	7.66
Crude protein	42.00
Crude fat	3.40
Crude fibre	19.00
NFE (nitrogen free extras)	22.34
Ash	5.60

3.2 Growth Performance

Average initial weight (W_o) and final fish weight (W_t) were calculated per hapa. The total stocking weight (TW) was maintained at the initial stocking weight by compensating the mortalities with fish of the similar size from the open pond. Mortalities were mainly experienced at the beginning of the experiment and the number of dead fish was replaced with live ones of the same size.

The growth performance of *O. niloticus* was determined in terms of relevant growth parameters (mean weight, weight gain, SGR, final mean length, daily weight gain, %gain in length, %gain in weight, and length gain). The growth performance parameters were calculated according to the following equations:-

Average Weight Gain (AWG) = Average final weight (g) – Average initial weight (g)

Average Daily Gain (ADG) = [Average final weight (g) – Average initial weight (g)] / time (days).

Specific Growth Rate (SGR %day⁻¹) = 100 [Ln W_t1 – Ln W_t0 / T]

Where: - Ln: normal log W_t0 : initial weight (g).

Wt 1: final weight (g) T: time of days.

3.3 Water quality parameters

Three water samples were collected in triplicates in 1m long column sampler at a depth of approximately 0.05m depths and at random positions of each hapa net. Each hapa net produced three samples collected at random areas as the rest of the nets, which is at 0.05 m depth. The triplicate samples from each hapa were mixed in a bucket and then sub-sampled into a 1-liter plastic bottle. The sample bottle was capped and taken to the laboratory for water quality analysis. The water samples were collected as stated above and analyzed fortnightly for total ammonia, dissolved oxygen, nitrite nitrogen, chlorophyll-*a*, pH and temperature. The water parameters were measured using standard methods described below:

3.4 Water Quality Analysis Procedures

The temperature in each hapa net was determined by dipping a 300mm laboratory chemical (mercury) glass thermometer (Elite Deluxe) into the hapa net. The thermometer reading would indicate the temperature of the water. This was done every fortnight.

Dissolved oxygen in each of the hapa net was measured in situ using an Oxygen Meter. The amount of oxygen would be recorded fortnightly to determine the changes in D.O as the fish continued to grow.

3.5 Bio-Chemical Water Quality Analysis

Nitrite-nitrogen was determined by a colorimetric method as described by Boyd and Tucker (2008). The principle behind this method is that nitrite-nitrogen reacts with diazotizing reagents in acidic solution to form diazonium salts. The salts are coupled with amino or hydroxyl groups of aromatic compounds to form colouredazo

compounds. The azo compound, which is pink, is proportional to the nitrite-nitrogen in the sample. The samples were collected using quarter sampling to get a representative sample from the hapa nets. Samples were collected in replicates of one litre and taken to the lab for analysis. Calorimeter (Hannah Instruments model Cal 1083C) was used to estimate the absorbance of these samples, which is usually proportional to the amount of Nitrite – nitrogen in the water sample. The same procedure was carried out to determine the level of nitrates and total ammonia.

3.6 Chlorophyll-*a*

Chlorophyll *a* was determined by the method described by (Ois, 2010). The principle in this method is that pigments and phytoplankton are extractable by acetone. To determine the chlorophyll-*a* a 100ml of the sample from each cage were filtered through a glass fibre put on filter holder attached to the funnel connected to the vacuum pump, which removes the liquid from the filter. Filtrates were removed, crumpled and placed into tissue grinders. A 5 ml aliquot of acetone were added and grounded thoroughly and left in the dark refrigerator overnight. The content were then transferred to 15 ml screw cap glass centrifuge tube and centrifuged at 3000 revolutions per minute for 10 minutes. The supernatant was decanted into 1 cm cuvette and absorbance read at 750 nm, 665 nm and 664 nm before and after acidification with 0.1 ml of 0.1 M HCL respectively. Phytoplankton biomass by a direct measure of the chlorophyll-*a* concentration. Chlorophyll *a* concentration was determined after extraction in 10 ml of 90% acetone using the formula:

$$\frac{26.7(665_a - 750_a) - (665_b - 750_b)^v}{V \times l}$$

Where,

665_a and 750_a = extinction at 665 and 750 nm before acidification respectively

665_b and 750_b = extinction at 665 and 750nm after acidification respectively

v = volume of the extractant (ml)

V = volume of water filtered (l)

l = length of light path (cm) or cuvette.

3.7 Fish length and weight

Fish for determination of length and weight were sampled fortnightly from the hapas and placed in a bucket container with adequate water. For each hapa, 50% of the fish were sampled using a scoop net. The hapas containing 30 fish, 15 fish samples were taken, those that were containing 60 fish, 30 fish samples were taken and those that had 90 fish, 45 fish samples were taken. Their total lengths (TL) to the nearest (cm) were measured using a ruler as illustrated in Plate 3.2. The body weight (W) of each sampled fish was measured to the nearest 0.01g using a beam weighing balance (Hannah Instruments model lab 13083C). Care was taken to avoid mortalities. This was done by taking the shortest time possible to take the readings and minimal handling of the fish.



Plate 3.2 Measuring and weighing of fish (Source: Author 2008)

The length-weight (log-transformed) relationships were determined by linear regression analysis and scatter diagrams of length and weight were plotted. The length-weight relationship of the experimented fish is worked out as per cube law given by Le Cren (1951).

$$W=aL^b$$

Where, W =Weight of fish (g), L is observed total length (cm), ' a ' is the regression intercept and ' b ' is the regression slope.

The logarithmic transformation of the above formula is-

$$\text{Log}W=\text{log}a+b\text{log}L$$

3.8 Specific growth rate (SGR)

Growth in wet weight of the fish was expressed as the specific growth rate (SGR % day⁻¹) using the formula

$$\text{SGR}=\frac{(\text{Ln } W_t-\text{Ln } W_0)}{t(100)}$$

Where Ln = natural logarithm;

W_0 = initial weight (mg),

W_t = final weight (mg)

Mean fry weight= average wt of fry at " t " days for the stocking density

Mean fry length = the average total length of fry at " t " days for the stocking density

Food Conversion Ratio (FCR)

FCR was computed from the results as follows:

$$\text{FCR}=\frac{\text{TFI}}{\text{WG}}$$

Where: TFI = Total feed ingested (g),

WG = Weight gain (g)

3.9 Survival

Number of fish that died were recorded as they occurred. The percentage survival was computed using the formula shown below.

$$\% \text{ survival} = \frac{\text{Initial number of fish in hapa net} - \text{Number of dead fish}}{\text{Initial number of fish in the hapa net}} \times 100$$

3.10 Condition factor

Condition factor was determined by the equation;

$$K_n = \frac{W}{a} TL^b \dots\dots\dots \text{Le Cren, (1951)}$$

K_n = Relative Condition Factor,

W = weight of fish (g),

TL = Total length of fish (cm),

a (intercept) and b = slope (exponent), a and b are constant of the regression equation

3.11 Data Analysis

Data was analysed for means using a statistical package for social scientists (SPSS 15). Variations in total length (TL), mean body weight (BW), survival and specific growth rate (SGR) respectively, were analyzed using two-way ANOVA at 5% level of significance.

CHAPTER FOUR

RESULTS

4.0 Growth performance

A summary of growth performance attributes of *O. niloticus* are illustrated in Table 4.1.

The stocking length of *O. niloticus* among the treatments was not statistically different. The same case applied for the stocking weights ($F=20$, $df= 2$, $p=0.001$). At the end of the experiment, the largest fish were recorded in 30 fish m^{-3} hapa nets and weighed 48.51g while the smallest fish were found in the treatment with the highest stocking density of 90 fish m^{-3} weighing 30.06 g. Fish stocked at 60 fish m^{-3} and 90 fish m^{-3} showed significant differences in gain in weight and in length ($F=20$, $df = 2$ $p=0.001$) and weight ($F=20,df= 2$, $p=0.001$).

Comparing the three treatments, the 30 fish m^{-3} had the highest gain in length of 28.46cm and a gain of weight of 48.51g respectively. After 16 weeks of experiment, the final lengths of *O. niloticus* were significantly different among the treatments ($F = 1263.782$, $df = 2$, $p= 0.001$).

Table 4.1 Growth performance (Mean±SE) of *O. niloticus* at three different stocking densities in hapas.

Parameter	Stocking densities		
	30 fishm ⁻³	60 fishm ⁻³	90 fishm ⁻³
Stocking length (cm)	10.46 ± 0.02 ^a	10.46 ± 0.02 ^a	10.31 ± 0.02 ^a
Stocking weight (g)	20.77 ± 0.02 ^a	20.60 ± 0.02 ^a	20.97 ± 0.02 ^a
Final length (cm)	28.46 ± 0.02 ^c	22.60 ± 0.06 ^b	19.12 ± 0.36 ^a
Final weight (g)	48.51 ± 0.19 ^c	33.0 ± 0.51 ^b	30.06 ± 0.36 ^a
Gain in length (cm)	18.0 ± 0.03 ^c	12.31 ± 0.07 ^b	8.81 ± 0.04 ^a
Gain in weight (g)	28.05 ± 0.19 ^c	12.40 ± 0.51 ^b	9.05 ± 0.36 ^a
% Gain in length	172.08	85.08	48.52
% Gain in weight	135.05	61.81	43.16
Daily gain in length (cm day ⁻¹)	0.05 ^c	0.03 ^b	0.02 ^c
Daily gain in weight (g day ⁻¹)	0.41 ^c	0.27 ^b	0.16 ^c
Specific Growth Rate (% day ⁻¹)	0.42 ± 0.03 ^c	0.30 ± 0.05 ^b	0.24 ± 0.03 ^a
Food Conversion Ratio	0.05 ^a	0.08 ^b	0.10 ^c

In each line for every experiment means with the same letters as subscripts are not significantly different.

The highest mean length was recorded in fish stocked at 30 fishm⁻³, while the lowest mean length was recorded in fish stocked at 90 fishm⁻³.

Fish in the 30 fishm⁻³ had the best specific growth rate of 0.42% day⁻¹ while those in the 90 fishm⁻³ had the least of 0.24% day⁻¹.

4.1 Gain in length

The fish were monitored for their increase in length throughout the experimental period. Figure 4.1 illustrates trend curves of the increase within the experimental period. 30 fish⁻³ had the best daily gain in length of 0.05cmday⁻¹ compared to the three treatments. The 90fishm⁻³ had the least gain of 0.16gday⁻¹ and 0.02cmday⁻¹.

The highest mean length recorded was 28.46cm in the 30fishm⁻³ and the lowest mean length was 19.12cm recorded in the 90fishm⁻³.

After 16 weeks of experiment, the final lengths of *O. niloticus* were significantly different among the treatments (F = 1263.782, df = 2, p= 0.001).

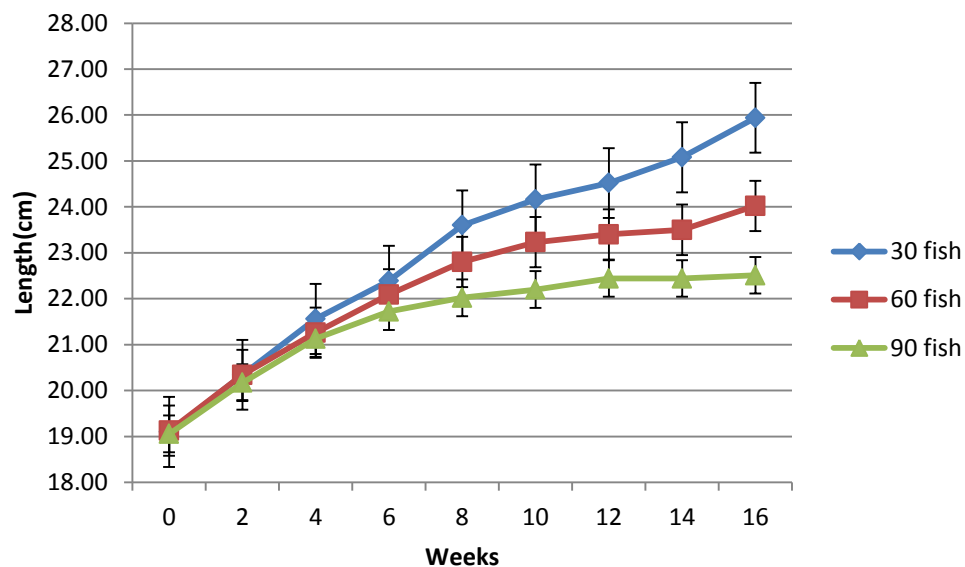

Figure 4.1 Growth in length of *O. niloticus* stocked at three different stocking densities in hapas in a pond. (Vertical bars represent standard deviation)

4.2 Gain in weight

Performance in weight was also monitored within the course of the experiment. The results are illustrated in Figure 4.2. The fish stocked at 30 fishm⁻³ had the best overall performance in weight gain and the fish stocked at 90 fishm⁻³ had the least level of weight gain. The fish stocked at 30 fishm⁻³ attained a weight of 48.15g and those stocked at 90fishm⁻³ attained a weight of 30.06g at the end of the experiment. There

was significant difference among the treatments in terms of weight gain. ($F = 1380.947$, $df = 2$, $p = 0.001$)

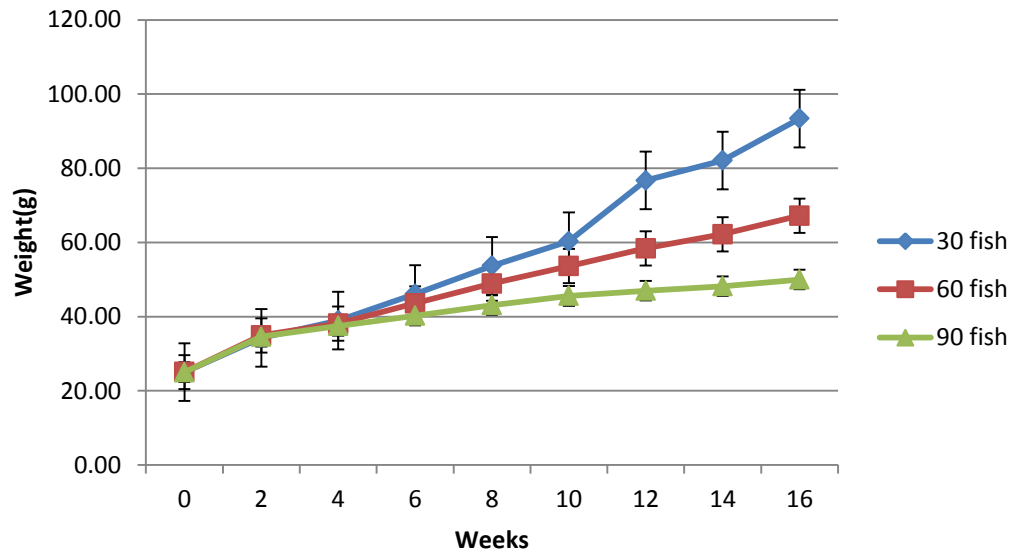

Figure 4.2 Growth in weight of *O. niloticus* stocked at three different stocking densities in hapas in a pond. (Vertical bars are standard deviations)

4.3 Length – weight relationships

Fish in all the hapa nets indicated a negative allometric growth with a regression coefficient of less than 3. All the fish indicated higher increase in length compared to the increase in weight. However, the rate of increase in length weight was different among the hapa nets as indicated by the different b values. Figure 4.3 gives an analysis of these results.

The general equation of $\text{Log } L$ versus $\text{Log } W$ indicated a b value of 2.0265 at 30 fish m^{-3} , 1.0828 at 60 fish m^{-3} , and 1.0596 at 90 fish m^{-3} . There was a significant difference in the b value among the hapas ($F=10.00$, $df = 2$, $p = 0.001$). As the stocking density increase from 30 fish m^{-3} to 90 fish m^{-3} , the b values continued to be progressively smaller than 3, indicating negative allometric growth. This can be attributed to the different condition factors within the hapa nets.

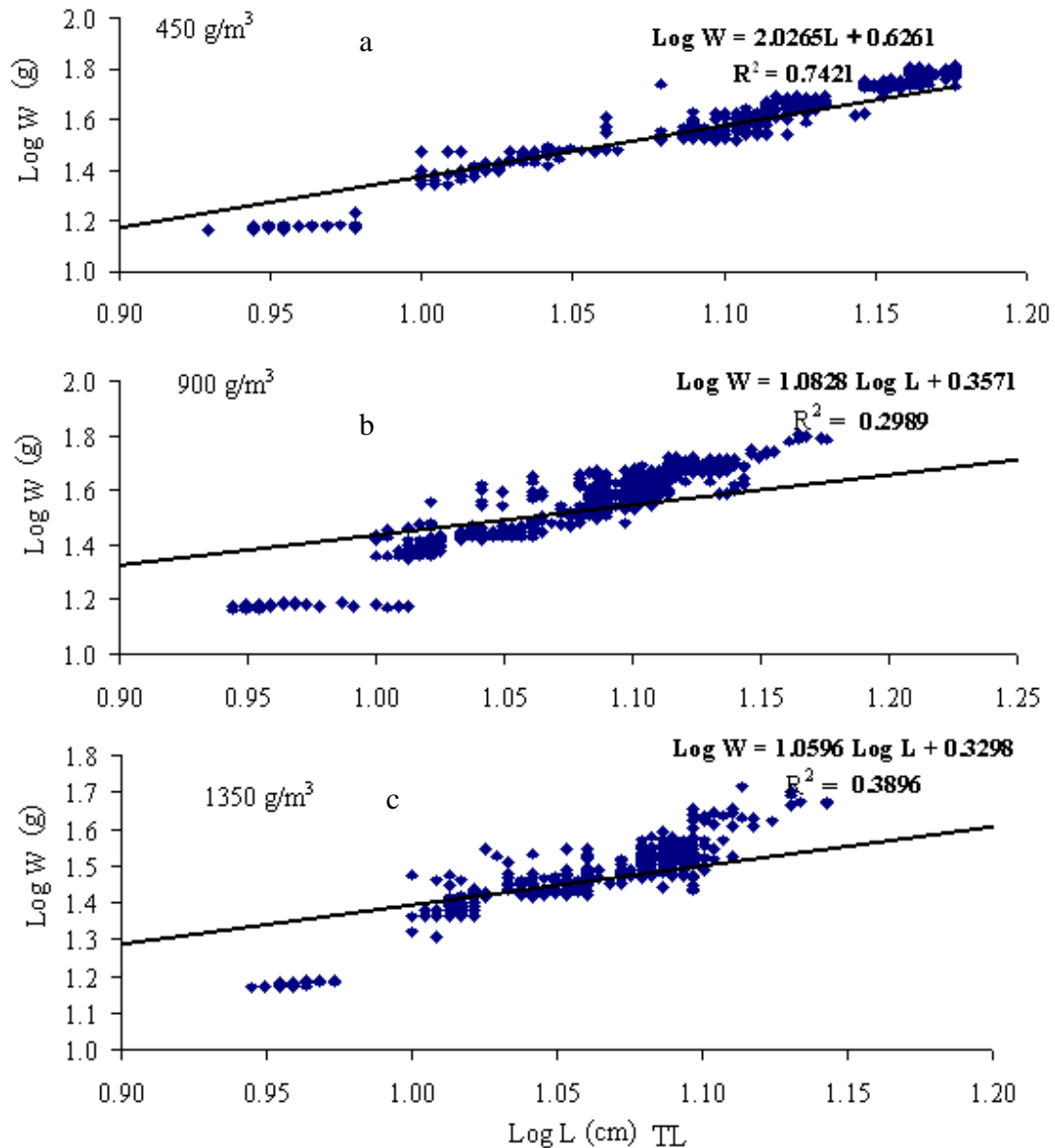

Figure 4.3 Log transformed length-weight relationships of *O. niloticus* reared in the hapas during the experimental period. a) fish stocked at 30 fishm⁻³ b) fish stocked at 60 fishm⁻³, c) fish stocked at 90 fishm⁻³

4.4 Food Conversion Ratio

Food Conversion Ratio (FCR) of *O. niloticus* stocked in hapas decreased with decreased stocking density. Fish stocked at 30 fishm⁻³ had an FCR of 0.05, which was the highest followed by fish stocked at 60 fishm⁻³ with FCR of 0.08 and finally fish stocked at 90 fishm⁻³ had the least FCR of 0.1. FCR among the three different treatment was statistically different ($F=10.00, df=2, p=0.001$).

4.5 Condition Factor

Trend curves for changes in the condition factor of *O. niloticus* under different stocking densities are illustrated in Figure 4.4. The fish stocked at 30 fish⁻³, 60 fish⁻³ and 90 fish⁻³ had condition factor of 1.2, 1.13 and 1.0 respectively. In all the three densities, condition factors indicated a considerable difference the first three weeks of the study.

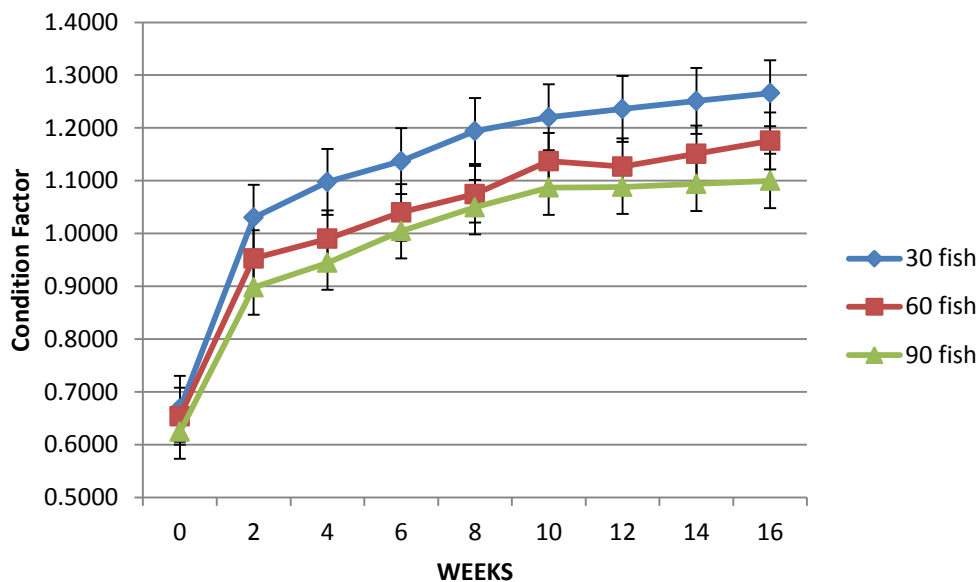

Figure 4.4 Trends in condition factors of *O. niloticus*, stocked at three different stocking densities reared in hapa nets. (The vertical bars represent standard deviation).

4.6 Survival

The fish stocked at a density of 90 fish⁻³ exhibited the lowest survival while those stocked at 30 fish⁻³ recorded the best survival. The survival trends at different stocking densities showed significant difference in the first 7 days (Figure 4.5). The trends showed a significant differentiation at 14 days ($F = 42.433$, $df = 2$, $p = 0.0014$). The survival trend curves for 90 fish⁻³ indicated a significant difference ($F = 3.443$, $df = 2$, $p = 0.043$) from that of 60 fish⁻³ since the onset of the experiment up to day 28. After 28th day of experiment, the trend curve for the survival of fish stocked

at 30 fish m⁻³, 60 fishm⁻³ and 90 fishm⁻³ did not show significant difference from each other. The trend curves in survival of fish under different stocking densities thereafter remained the same until the end of the experimental period.

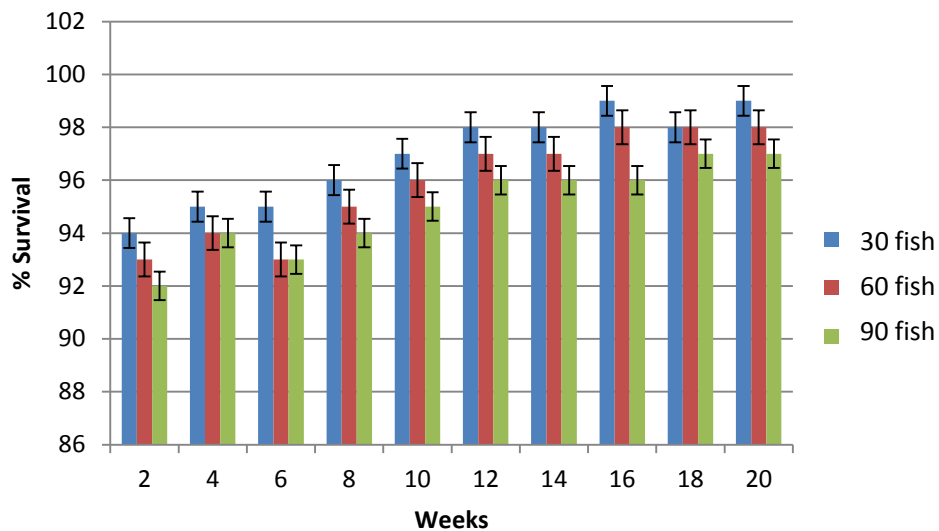

Figure 4.5 Survival of *O. niloticus* under three stocking densities in hapa net

4.7 Chlorophyll-*a*

Phytoplankton was estimated as chlorophyll-*a*, a photo-pigment used for photosynthesis and present in all groups of algae and results illustrated in Figure 4.6. Chlorophyll-*a* in all the treatments varied among the hapas with the highest being in the hapas stocked at 30 fishm⁻³ (1.27μgL⁻¹) and the lowest being in hapas stocked at 90 fishm⁻³ (1.17μgL⁻¹). Those that were stocked at 60 fishm⁻³ had an average level of 1.19μgL⁻¹. There were no significant differences in the trends among the treatments within the course of the experiment (F=10.00, df =2, p = 0.5021).

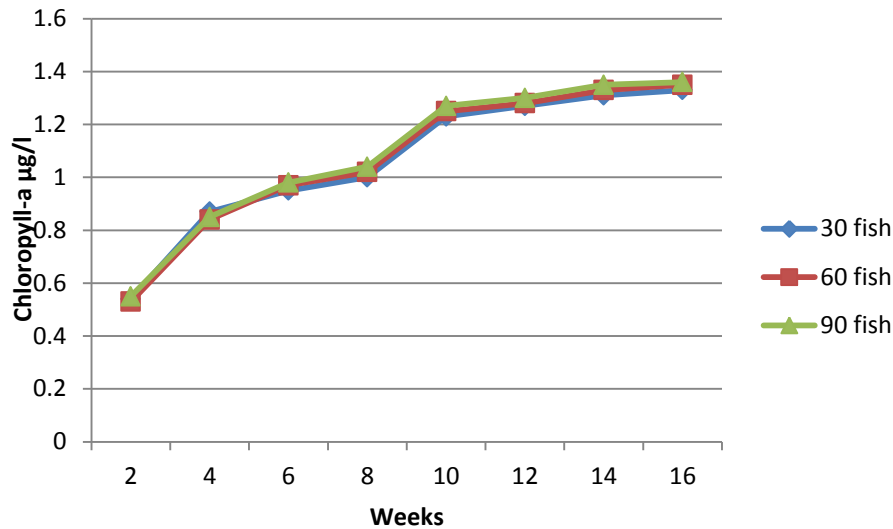

Figure 4.6 Chlorophyll-a levels under the three stocking densities

4.8 Water quality changes

4.8.1 TAN-N

Total Ammonia Nitrogen (TAN-N) within the hapas had a range of 0.3-1mgL⁻¹ with the hapas stocked at 90 fishm⁻³ recording the highest amount of ammonia nitrate of 1.0 mgL⁻¹. The lowest hapa stocked at 30 fishm⁻³ recorded the least TAN-N amount of 0.3 mg/l. Those stocked at 60 fishm⁻³ recorded TAN-N amount of 0.5 mgL⁻¹.

TAN-N displayed significant differences among the stocking density treatments (F=10, df=2, p= 0.0401) as represented in Figure 4.7. TAN-N was significantly higher in hapas stocked at 60 fishm⁻³ and 90 fishm⁻³ when compared to hapas stocked at 30 fishm⁻³(F=10, df=2, p= 0.0311).

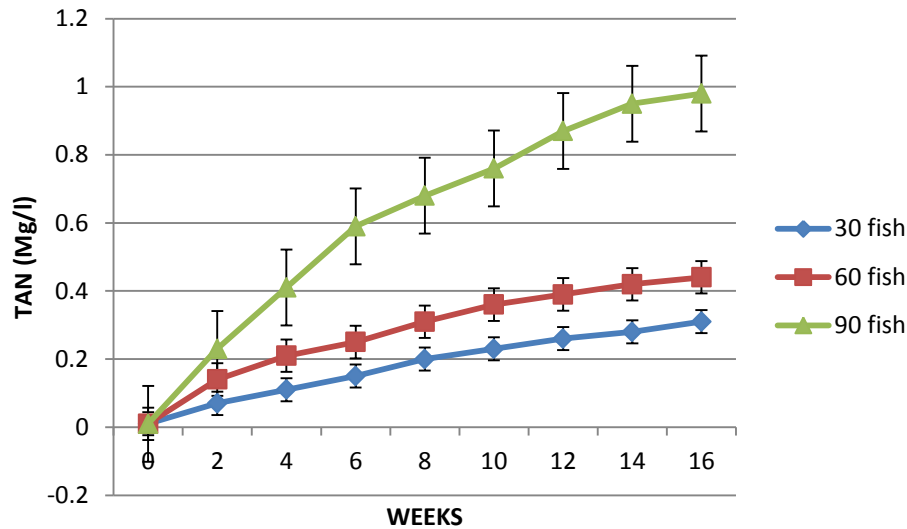

Figure 4.7 Total Ammonium Nitrate in within the hapa nets. (The vertical bars represent standard deviation)

4.8.2 Dissolved Oxygen

The overall range of oxygen during the study was 2-11 mgL⁻¹ (Figure 4.8). The hapas stocked at 90 fishm⁻³ showed the greatest change recording 2mgL⁻¹ at the end of the experiment and had an average of 6.21± 0.2 mgL⁻¹ while the hapa stocked at 30 fishm⁻³ had an average of 8.32± 0.2 mgL⁻¹) and showed the least change recording 5 mgL⁻¹ at the end of the study. Those stocked at 60 fishm⁻³ recorded oxygen level of 3mgL⁻¹ at the end of the study and had an average of 7.12 ±0.2 mgL⁻¹. There was no significant change in the hapas stocked at 30 fishm⁻³(F=20 df=2, p=0.5124) while the other two stocking densities showed significant changes for D.O throughout the experiment (F=20, df=2, p=0.032).

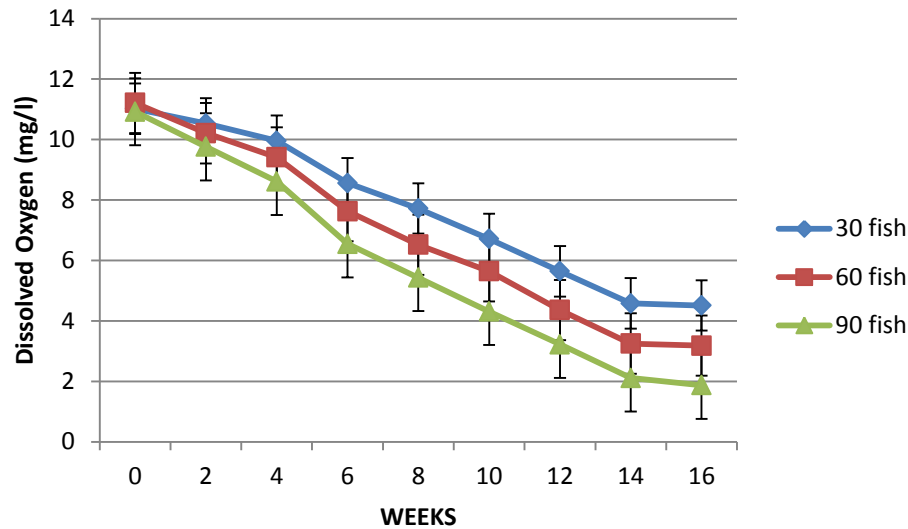

Figure 4.8 Dissolved oxygen levels within the hapa nets. (The vertical bars represent standard deviation)

4.8.3 pH

The general range for pH within the treatments was 5.5-6.3 (Figure 4.9). The average pH level of 30 fish^m⁻³ and 60 fish^m⁻³ was 5.92 ± 0.1 and 5.81 ± 0.1 respectively. These two stocking densities recorded a change of 0.4 in pH at the end of the experiment. The 90 fish^m⁻³ had an average of 5.63 ± 0.1 and had the highest pH level change of 0.6. The pH within the treatments did not display any significant differences, ($F=10$, $df=2$, $p=0.0521$).

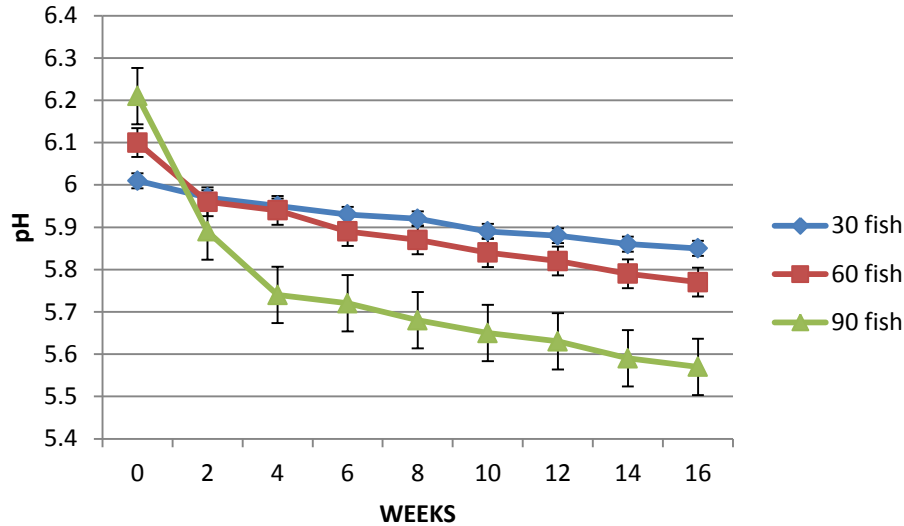

Figure 4.9 Variation of average pH values with time. (The vertical bars represent standard deviation)

4.8.4 Temperature

The average temperatures recorded are illustrated in Figure 4.10. There was no significant temperature changes within the hapa nets ($F=10$, $df=2$, $p=0.0513$). The first, eight and tenth weeks of the experiment recorded significant differences ($F=10$, $df=2$, $p=0.0412$) in temperature changes as compared to the other readings taken. The highest temperature recorded was 25.3°C which was in the second week of the study. The lowest temperature was recorded in the eight week of the study which was 22.8°C . The fourth month of the study had the highest recorded temperature which averaged 24.3°C and the lowest recorded temperature was in the third month of the study which averaged 23.1°C .

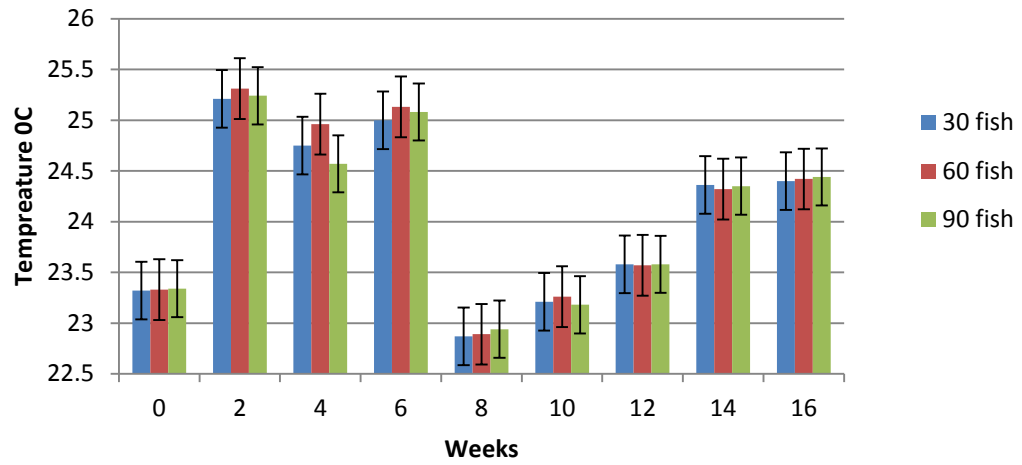

Figure 4.10 Mean weekly temperatures within the hapa nets.

CHAPTER FIVE

DISCUSSION

The observed final weight, lengths and SGR were significantly poor in the highest stocking density of 90 fishm⁻³. These results were attributed to several factors. High densities of fish led to crowding which may have reduced fish appetite leading to poor feeding which may have given rise to poor feed conversion. Reduced space in the hapa nets resulted into space limitation and other adverse physical chemical conditions which may have caused stress to the fish. Cato & Brown, 2013 reported the same finding on 20g *O. niloticus* stocked in hapa nets at the same densities. Uneaten food could have led to ammonia build up leading to poor growth. Studies done by Youssouf, (2007) showed that stress is caused by the accumulation of toxic ammonia and nitrite resulting from uneaten food led to poor growth.

The growth performance of the *O. niloticus* at the 30 fishm⁻³ had a better growth performance compared to the other two stocking densities suggesting that 30 fishm⁻³ can be used as a probable stocking density. This is similar to what was seen for *O. aureus* stocked at 30 fishm⁻³ in marine hapas where the growth performance was not affected by stress factors such as toxic ammonia and nitrite (Anderson *et al.*, 2010). In freshwater, Gibson (2005) found no differences in growth or feed conversion of *O. niloticus* reared in cages at densities of 30 fishm⁻³ compared to 60 fishm⁻³ and 90 fishm⁻³.

Anderson *et al* (2010) recommended 3.0 mgL⁻¹ as a minimum D.O. level below which adverse affects appear during cage culture of tilapias in fresh water. In this study, the hapa nets with stocking densities of 60 fishm⁻³ and 90 fishm⁻³, D.O. fell below 3.0

mg/l., which could be attributed to high stocking densities. This low level of DO may suggest the reason for poor growth and survival of the fish.

The results demonstrated that fish that were stocked at 30 fishm⁻³ had the highest growth rates in terms of weight gain and increase in length. This stocking density also had the most favourable conditions with respect to physical – chemical parameters.

Fish reared in all the hapa nets yielded negative allometric growth. This means that the fish increased in length at higher rate than they increased in weight. The lower stocking densities of 30 fishm⁻³ had the highest *b* value compared to other stocking densities which implies the best performance in terms of growth amongst all the treatments. On the other hand, Fish in the 60 fishm⁻³ and 90 fishm⁻³ had progressively smaller *b* values. This implies that the fish gained weight at a far much lesser rate as compared to that of length. This may be attributed to higher stocking levels which led to overcrowding and increased stress levels hence the poor weight gain.

The condition factor shows the degree of well-being of the fish in their habitat. This factor is a measure of various ecological and biological factors such as degree of fitness, gonad development and the suitability of the environment with regard to the feeding condition (Gregory & Grandin, 2013). From the study, fish in the 30 fishm⁻³ portrayed a condition factor of 1.2, which was the best, compared to the other two. This again can be attributed to the low stocking density than that of 60 fishm⁻³ and 90 fishm⁻³. The higher condition factor in the fish stocked at 30 fishm⁻³ could be attributed to low level of ammonia 0.05mg/l⁻¹. *O. niloticus* thrives best at levels of 0.05mg/l⁻¹ of ammonia or lower in semi intensive culture (Giorgio & Williams, 2005). Above this level, there is a significant change in the fish growth in terms of weight

and length.

Tilapia performs best in pH of about 7 (Green, 2009). Ammonia, an acidic product, can lower the pH level, and become toxic. The pH of the water within the hapa nets could also have been influenced by the change in ammonia levels. From the study, low pH and ammonia levels did not affect the fish growth.

The minimum D.O requirements of tilapia species is 5 mg/l and if the concentration of D.O decreases, respiration and feeding activities also decrease (Ma *et al.*, 2006). Fish are unable to assimilate the food consumed when D.O is low (New and Valeti, 2008). Dissolved oxygen in the water plays a key role in the fish development. Hapa nets containing 60 fishm⁻³ and 90 fishm⁻³ recorded the lowest levels of dissolved oxygen, which may have contributed to the stress levels. High stocking density implied high oxygen consumption in the water and hence the low oxygen levels.

From the study, the temperature ranged between 23⁰C to 26⁰C. The optimal temperature for growth of tilapia ranges from 29⁰C to 31⁰C. In this study, the recorded temperature is lower than optimum temperature needed for tilapia growth. The low temperatures affected the growth of the fish in all hapas negatively. The lethal minimum temperature for most species of tilapia is 10⁰C or 11⁰C, while at 37⁰C to 38⁰C, stress and diseases sets in (World fish centre, 2009). None of these temperature conditions was reached and it may therefore be inferred that extreme temperatures did play any role in the growth performance of the fish.

From the study there were no significant differences in the treatment with respect to

phytoplankton. During phytoplankton busts, both ammonia and Carbon dioxide are liberated into the water column. Because freshwater has low buffering effect, Carbon dioxide can accumulate in the water, thus lowering the pH in ponds considerably and reducing the amount of un-ionized ammonia (New & Valenti, 2013). In this study, there was no phytoplankton busts that were observed.

CHAPTER SIX

CONCLUSION

1. The results from this study supported the hypothesis that stocking density has an effect on growth performance of *Oreochromis niloticus* stocked in hapa nets. The fish stocked at 30 fishm⁻³ had the highest growth rate amongst the three stocking densities. This is with respect to the gain in weight and length with time. Increasing the stocking densities to 60 fishm⁻³ and 90 fishm⁻³ led to a decrease in growth rate. It can be deduced that the 30 fishm⁻³ would be preferable stocking density of fish reared in hapa nets for this study.
2. From this study, the best survival of the fish was recorded in the fish stocked at 30 fishm⁻³ and lowest at 90 fishm⁻³. This supports the hypothesis that stocking density has an effect on the survival and growth of *O. niloticus* stocked in hapa nets.
3. Fish stocked at 30 fishm⁻³ favourable physical – chemical parameters compared to the other two stocking densities. Dissolved oxygen, Total Ammonium Nitrates and pH are some of the physical chemical parameters that were monitored. From the results, fish in the 30 fishm⁻³ did show significant differences in these parameters. They did not affect the growth performance of the fish, which implies that they were within the range that the fish could thrive in. The 60 fishm⁻³ and 90 fishm⁻³ hapa nets did not show significant differences with respect to the physical chemical parameters. This may imply that physical chemical parameters from high stocking density may have affected the growth performance of the fish.

RECOMMENDATIONS

From the study, temperature may have been a limiting factor and so improving on the temperature levels may lead to different results being observed. Tilapia thrive at temperatures averaging 28⁰C (Ma *et al.*, 2006). The temperatures in this study averaged 23⁰C. Conducting the study within a green house environment may help investigate this since the green house effect would help raise the water temperature.

The fish that were investigated were 20 day old fry. A study with bigger size of fish would be recommended to find out whether the stocking size would improve on the growth and mortality of the fish. Large size fish acclimatize fast to new environments and are quite resistant to handling stress so this may reduce the mortalities (World fish centre, 2009).

Investigating other stocking densities, may be 30 fishm⁻³ and below may give different observations in regards to growth performance and effects of physical chemical parameters on the same. This is considering the fact that the 30 fishm⁻³ had the best performance from this study. Fewer fish stocked are bound to have a lower cost of stocking and from the study, lower mortalities were observed. The overall cost of stocking is bound to be lower and higher returns expected.

REFERENCES

- Anderson, E., Stoskopf, M., Morris J., Clarke, E. & Harms, C. (2010) Hematology, Plasma Biochemistry, and Tissue Enzyme Activities of Invasive Red Lionfish Captured off North Carolina, USA. *Journal of Aquatic Animal Health* 22 (4). Pp 266-273
- ADCP (2003) Fish feeds and feeding in developing countries - An Interim Report on the ADCP Feed Development Programme. Project reports (not in a Series) - ADCP/REP/83/18.
- AOAC (2000) Food Energy - methods of analysis and conversion factors. Report of a technical Workshop, Rome, 3-6 December 2002,
- Cato, J. & Brown, C. (2013). *Marine Ornamental Species Collection, Culture and Conservation*. Hoboken: John Wiley & Sons.
- Clark, A., W.O. Watanabe, B., Olla, & Wicklund, R. (2008) *Growth, feed conservation, and protein utilization of Florida red tilapia fed isocaloric diets with different protein levels in seawater pools*. Aquaculture. MA: Havard UP.
- Edward A. (2008) *Principles of aquaculture improvement*. MA: CABI Publishers.
- FAO (2013) *Aquaculture production*. Yearbook of Fishery Statistics - Vol.92/2 Rome, FAO. 2013 186p.

- Gibson, R. (2005). *Flatfishes biology and exploitation*. Oxford, UK Ames, Iowa: Blackwell Pub.
- Giorgio, P. & Williams, P. (2005). *Respiration in aquatic ecosystems*. Oxford New York: Oxford University Press.
- Green, B. (2009). *Tropical fish otoliths information for assessment, management and ecology*. Dordrecht: Springer.
- Gregory, N. & Grandin, T. (2013). *Animal welfare and meat production*. Wallingford, Oxfordshire, UK Cambridge, MA: CABI.
- Houlihan, D., Boujard, T. & Jobling, M. (2010). *Food intake in fish*. Oxford Malden, MA: Blackwell Science.
- Houlihan, D., Boujard, T. & Jobling, M. (2013). *Food intake in fish*. Oxford Malden, MA: Blackwell Science.
- Jamu T. (2008) The exploratory Soil Map and Agro-climatic Zone Map of Kenya. Longhorn Printers, Nairobi. Pp 56-90.
- Kenya B. (2007) *Consideration of African Aquaculture*. World Aquaculture. New York: Random

- Ma, A., Lee, J. & Pederson A. (2006) *Effect of stocking density in aquaculture. Principles and Procedures*. Aquaculture Research Centre, Washington: St. Martins
- Marshima O. (2005). Effects of open-pond density and caged biomass of Nile Tilapia (*Oreochromis niloticus* L.) on growth, feed utilization, economic returns and water quality in fertilized ponds. *Aquaculture Research*. 36. 1535-1543.
- Mukoro, A. (2008) Effects of stocking densities on growth and survival of juvenile Nile Tilapia (*Oreochromis niloticus*, Linnaeus 1758) in cages. MPhil, Moi University, Kenya, Unpublished thesis.
- Nakabungo J. G. (2005). An alternative life history approach to the nutrition and feeding of Siluroidei larvae and early juveniles. In: The biology and culture of catfishes. M. Legendre J.P. Proteau (Eds.). *Aquatic living Resources* 9. Pp 121-133.
- New M. & Valenti, W. (2012). *Freshwater prawn culture the farming of Macrobrachium rosenbergii*. Malden, MA: Blackwell Science.
- New M. (2010). *Freshwater prawns biology and farming*. Chichester, U.K. Ames, Iowa: Wiley-Blackwell Pub.
- Ois, N. (2010). *Finfish aquaculture diversification*. Wallingford, UK Cambridge, MA: CABI.

- Omwansa D. (2005). Comparative study of the effect of stocking density on growth performance of *O. niloticus*. *Aquaculture Research*. 34.Pp 1223-1229.
- Rensen, S., Tundisi, J. & Tundisi, T. (2013). *Handbook of inland aquatic ecosystem management*. Boca Raton: CRC Press, Taylor & Francis Group.
- Sayed B. (2006). *Tilapia culture*. Wallingford, UK Cambridge, MA: CABI Pub.
- Shisia A., & Ngure V. (2011) *Contribution of soil water to contamination of ground water in Uasin Gishu District*. Agape publishers: Kenya.
- Wanniggama H., Hossain M., Batty R., Haylor G. & Beveridge M. (2006). Diel feeding activity of African (catfish *Clarias gariepinus*). *Aquaculture Research*, 20. 901-902.
- World Fish Centre. (2009). *Rearing of Tilapia Fry in ponds*. World fish Centre. New York.
- Youssof S., Caleb L., & Cathy R. (2007) *Fish Physiology*. State Printers. New York.
- Ziková A., Lorenz C., Lutz I., Kloas W. (2010) *Primary biomass producers in aquaculture*. MA: Havard.